

**VOLTECK** CÓDIGO: 40016 CLAVE: PA-CODO-CLP

**Placa armada contacto dúplex, 2 polos + tierra Classic**

- Fabricado en policarbonato

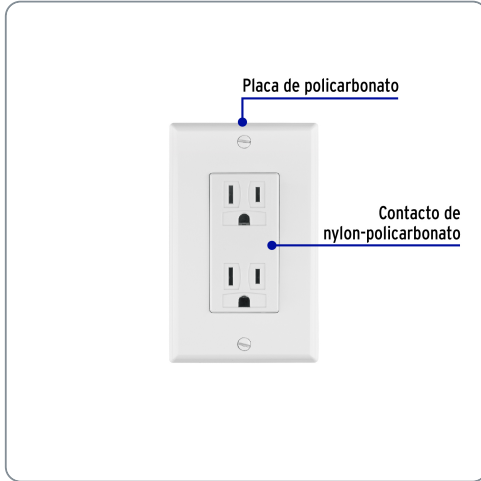

Datos de empaque	
Empaque Individual: Bolsa	
Empaque logístico	Cantidad
Inner	3
Master	48
Pallet	2592

**Certificaciones y garantías**

Cumple la norma: NOM-003-SCFI

Producto fabricado en China bajo las estrictas especificaciones de Truper



Especificaciones técnicas	
Tensión / Frecuencia	127 V / 60 Hz
Corriente	15 A

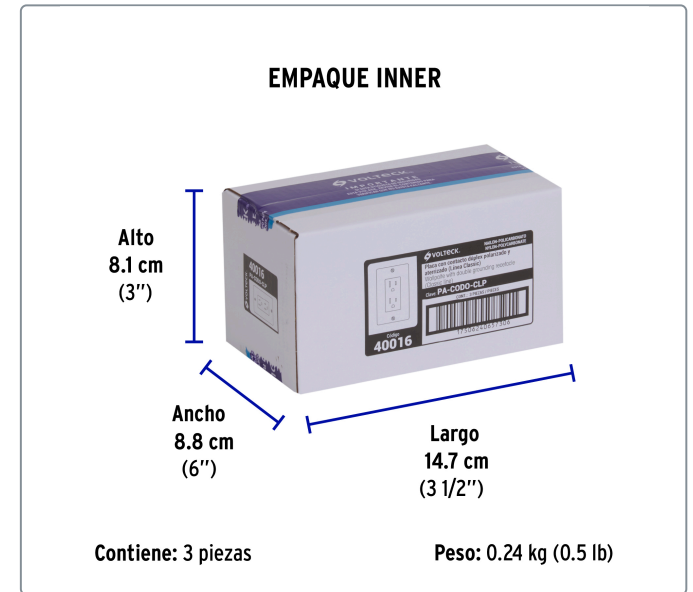
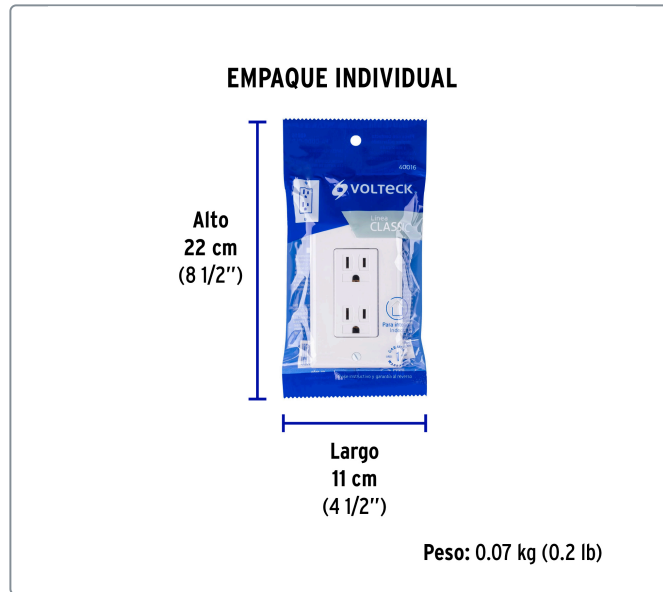
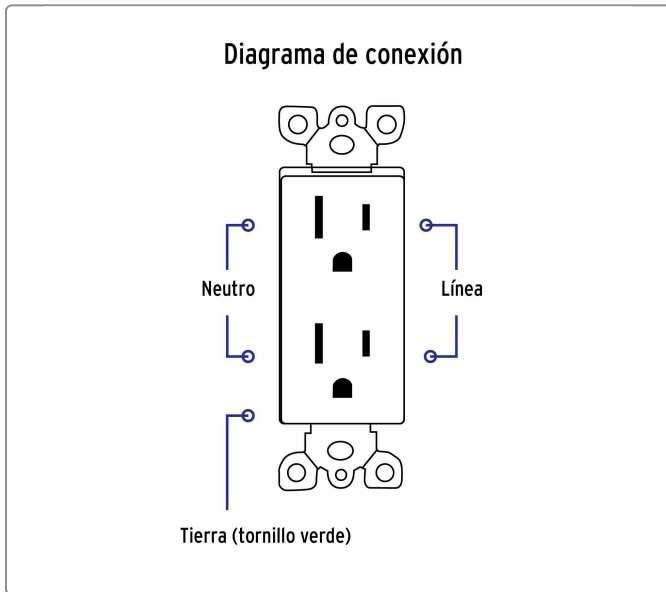
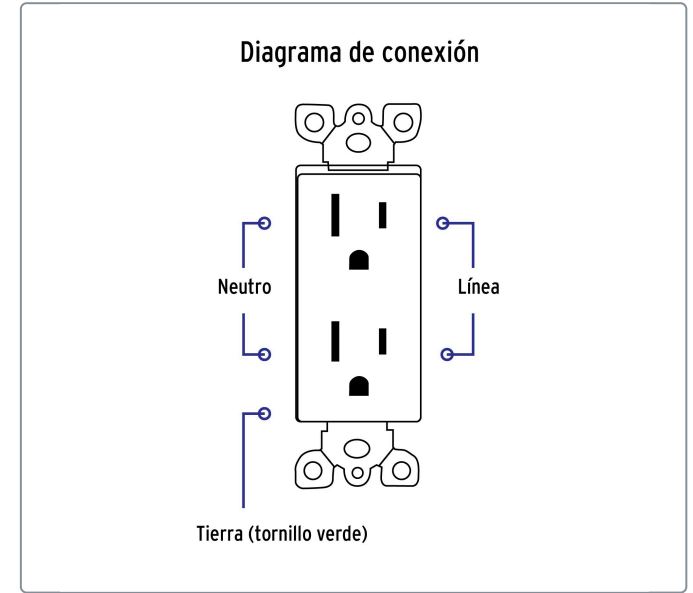
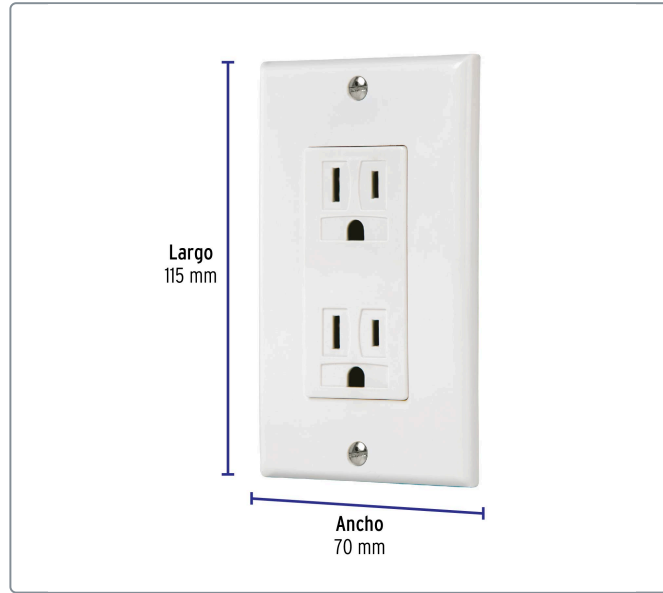
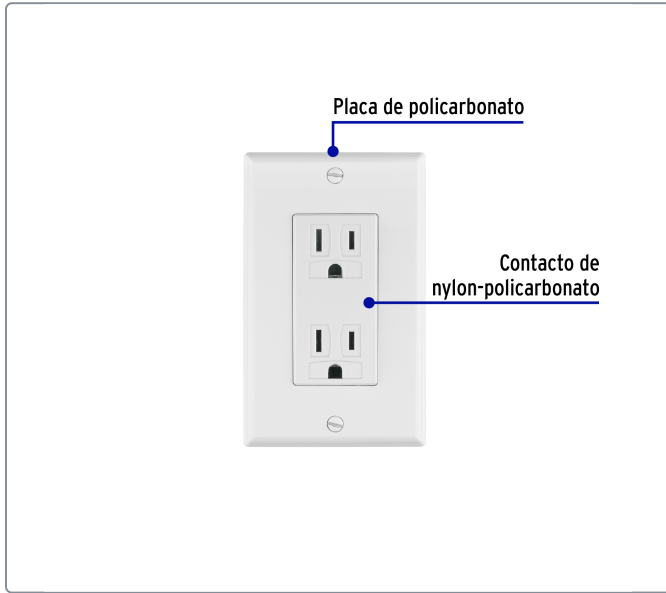

**EMPAQUE MASTER**



Contiene: 16 inner (48 piezas)

Peso: 4.2 kg (9.3 lb)

