

**VOLTECK** CÓDIGO: 48490 CLAVE: PA-CODO-MS

**Placa armada contacto dúplex, 2 polos, línea Standard, marfil**

- Placa de ABS, contacto de nylon/policarbonato

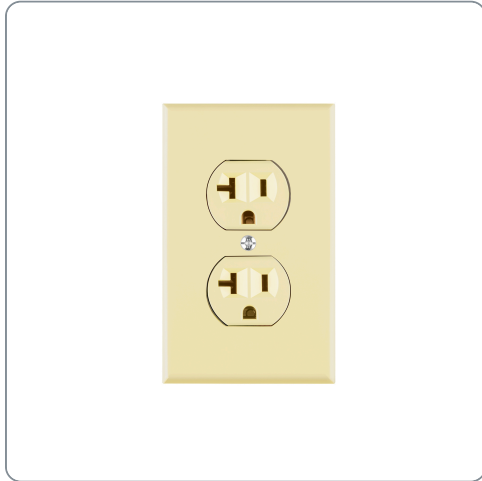

Datos de empaque	
Empaque individual: Bolsa	
Empaque logístico	Cantidad
Inner	3
Máster	72
Pallet	3456

**Certificaciones y garantías**

Cumple la norma: NOM-003-SCFI



Producto fabricado en China bajo las estrictas especificaciones de Truper

**Línea Standard**

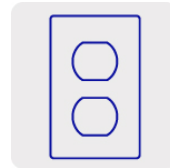

Especificaciones técnicas	
Tensión / Frecuencia	127 V / 60 Hz
Corriente	20 A

