

VOLTECK CÓDIGO: 48495 CLAVE: PA-COAP-SA

Placa armada interruptor y contacto, línea Standard, aluminio

- Placa de aluminio, contacto e interruptor de nylon/policarbonato

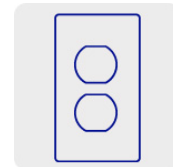

Especificaciones técnicas	
Interruptor: Tensión / Frecuencia	120 V / 60 Hz
Contacto: Tensión / Frecuencia	127 V / 60 Hz
Corriente	15 A

Datos de empaque	
Empaque individual: Bolsa	
Empaque logístico	Cantidad
Inner	3
Máster	72
Pallet	2160

Certificaciones y garantías



- Cumple la norma: NOM-003-SCFI

Producto fabricado en China bajo las estrictas especificaciones de Truper

Diagrama de conexión

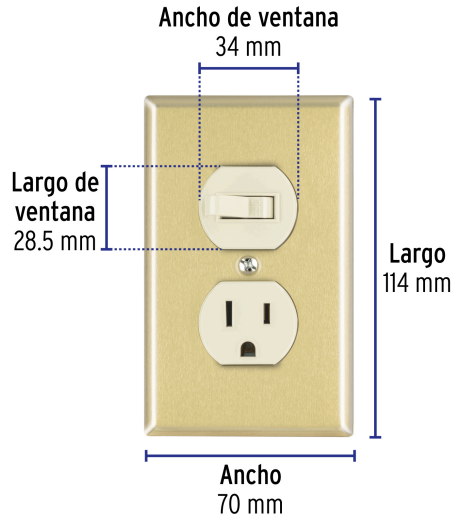
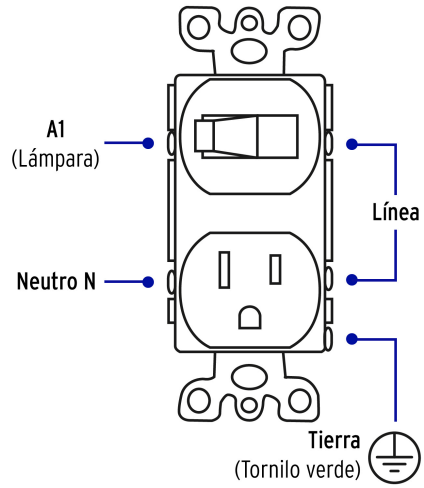

EMPAQUE INDIVIDUAL



Peso: 0.09 kg (0.2 lb)

EMPAQUE INNER



Contiene: 3 piezas

Peso: 0.3 kg (0.7 lb)

EMPAQUE MASTER



Contiene: 24 inner (72 piezas)

Peso: 7.78 kg (17.2 lb)