

VOLTECK CÓDIGO: 45594 CLAVE: PA-APCO-E3B

Placa armada 1 interruptor, 2 contactos, 1 mod, Española, blanco

- Fabricada en policarbonato
- 1 Interruptor y 2 contactos
- Indicador nocturno fluorescente



Línea Española



Especificaciones técnicas	
Tensión	127 V contacto / 127 V interruptor
Corriente del interruptor	15 A contacto / 10 A interruptor
Frecuencia	60 Hz
Altura del módulo	23 mm
Dimensiones de la placa (largo x alto)	73 x 118 mm

Datos de empaque	
Empaque individual: Bolsa	
Empaque logístico	Cantidad
Inner	3
Máster	72
Pallet	2592

Certificaciones y garantías



- Cumple la norma: NOM-003-SCFI

Fabricado en China bajo las estrictas especificaciones de GRUPO TRUPER

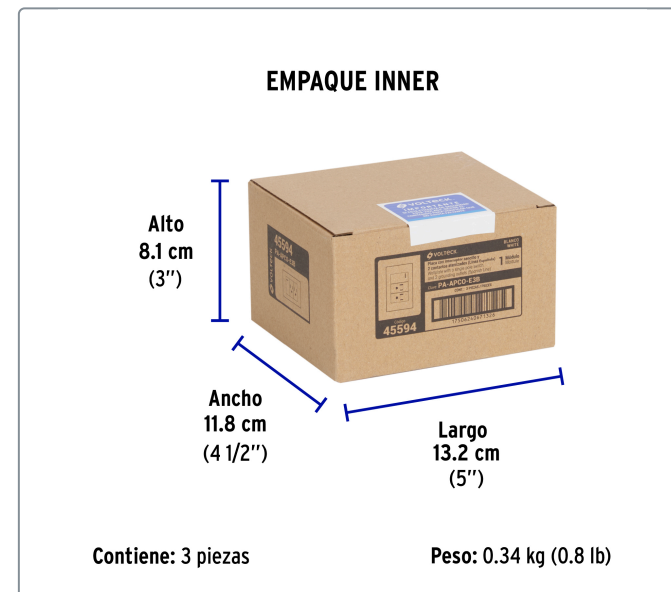
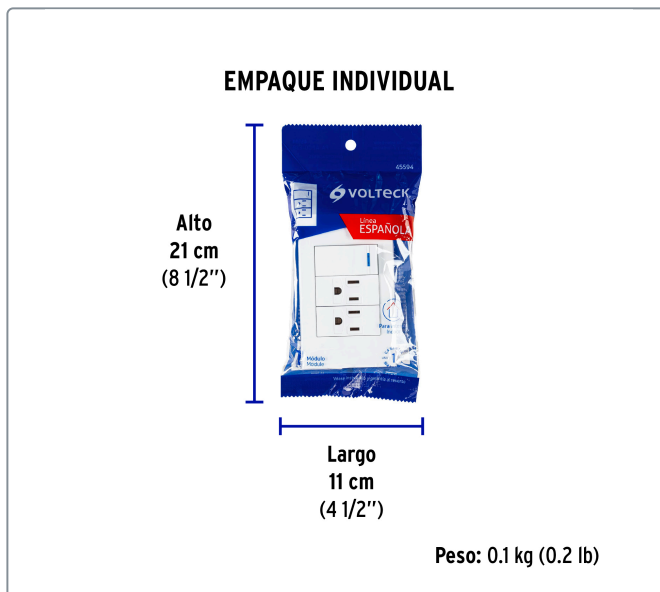
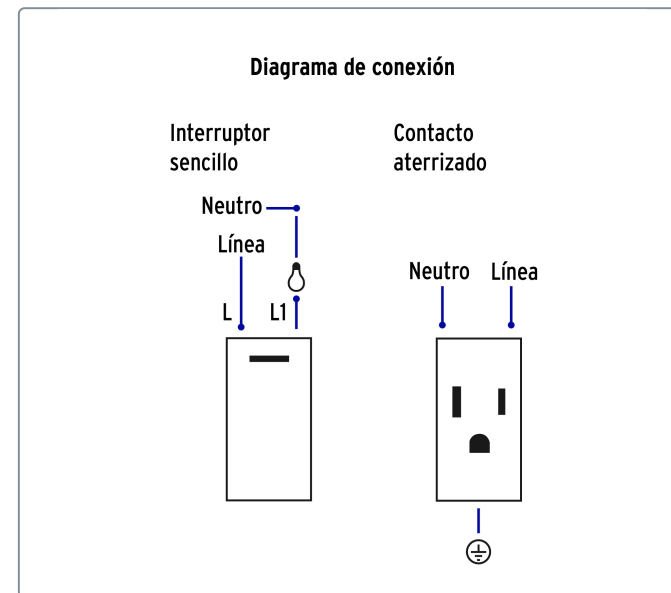
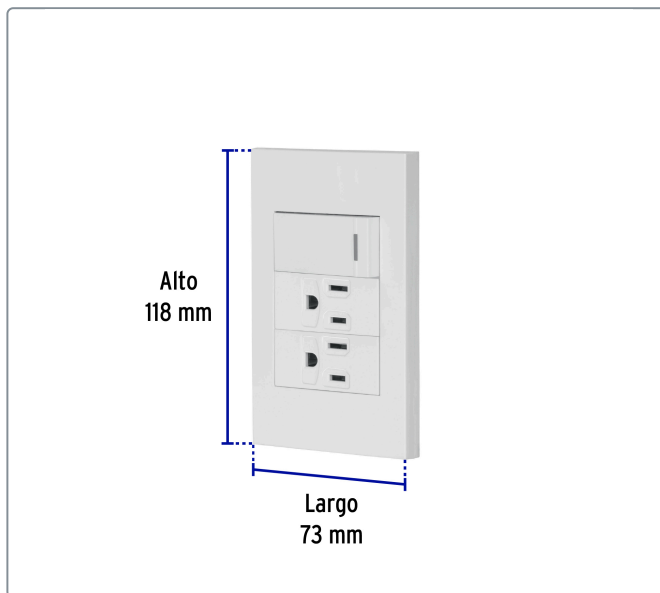
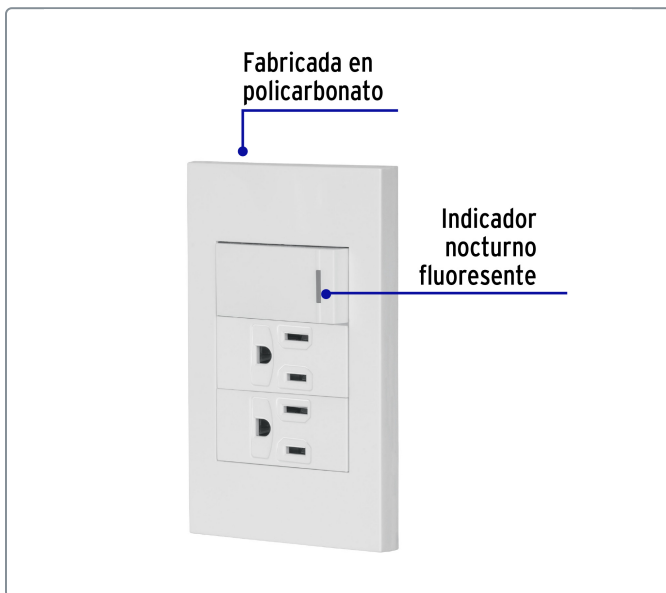

EMPAQUE MASTER



Contiene: 24 inner (72 piezas)

Peso: 8.7 kg (19.2 lb)