

VOLTECK CÓDIGO: 45602 CLAVE: PA-APD01-EEB

Placa armada 2 interruptores 1de 3vías,1 mod,Española,blanco

- Fabricada en policarbonato
- Indicador nocturno fluorescente
- 2 Interruptores

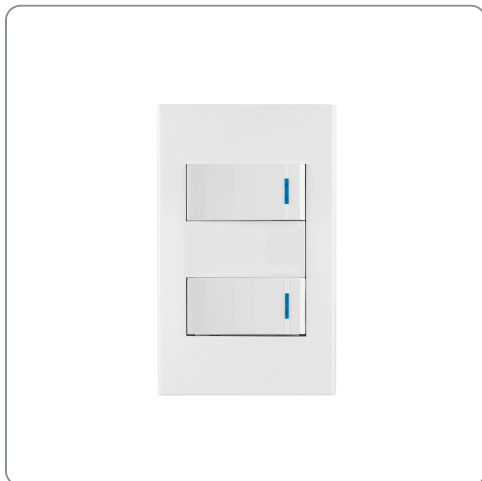

Línea Española



Especificaciones técnicas	
Interruptores	3 Vías y sencillo
Tensión / Frecuencia	127 V / 60 Hz
Corriente	10 A
Altura del módulo	23 mm
Dimensiones de la placa (largo x alto)	73 x 118 mm

Datos de empaque	
Empaque individual: Bolsa	
Empaque logístico	Cantidad
Inner	3
Máster	72
Pallet	2808

Certificaciones y garantías

Cumple la norma: NOM-003-SCFI

Fabricado en China bajo las estrictas especificaciones de GRUPO TRUPER

Los productos ilustrados y la información pueden cambiar sin previo aviso, como resultado de nuestros procesos de mejora continua.

Prohibida su reproducción o divulgación total o parcial, así como su uso o aprovechamiento sin autorización escrita de Truper, S.A. de C.V.

© 2026 TRUPER, S.A. DE C.V. TODOS LOS DERECHOS RESERVADOS.

