

**VOLTECK** CÓDIGO: 45606 CLAVE: PA-APTR-EEB

**Placa armada 3 interruptores 1 de 3vías,1 mod,Española,blanco**

- Fabricada en policarbonato
- Indicador nocturno fluorescente
- 2 Interruptores sencillos y 1 de 3 vías

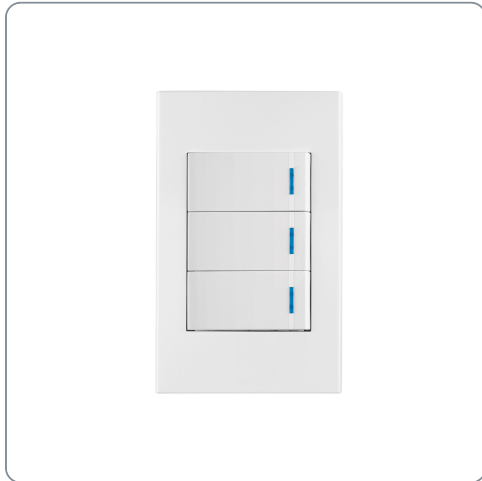

Datos de empaque	
Empaque individual: Bolsa	
Empaque logístico	Cantidad
Inner	3
Máster	72
Pallet	2808

**Certificaciones y garantías**

- Cumple la norma: NOM-003-SCFI

Fabricado en China bajo las estrictas especificaciones de GRUPO TRUPER



Especificaciones técnicas	
Tensión / Frecuencia	127 V / 60 Hz
Corriente	10 A
Altura del módulo	23 mm
Dimensiones de la placa (largo x alto)	73 x 118 mm

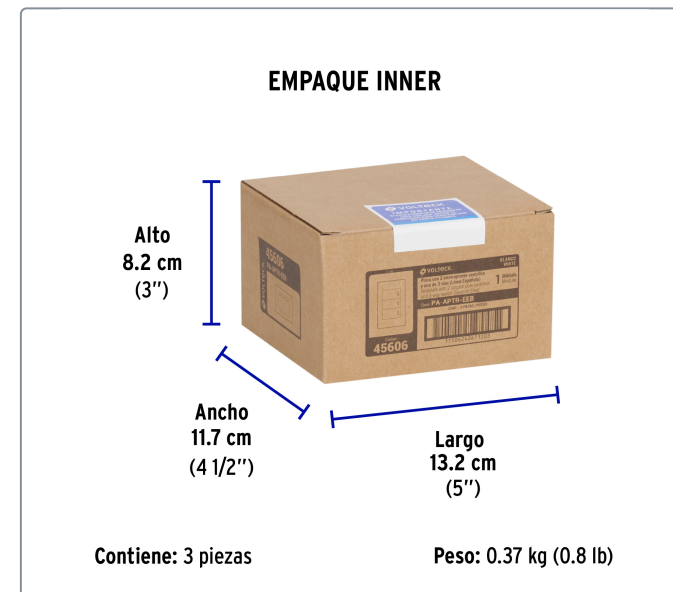
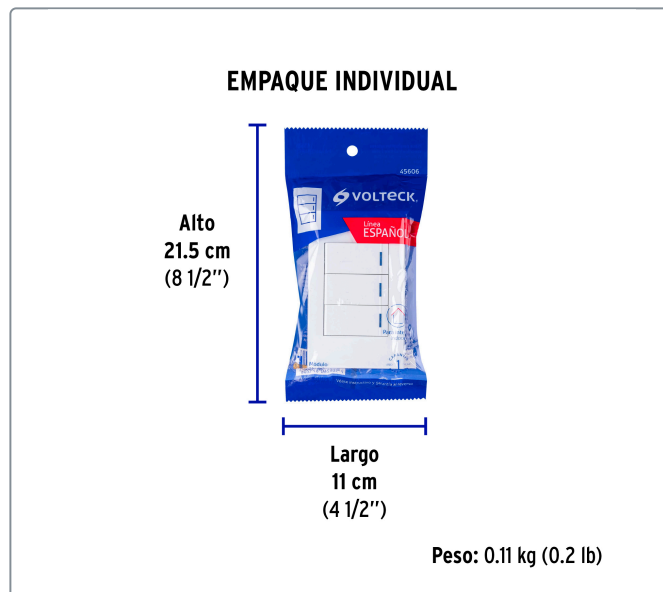
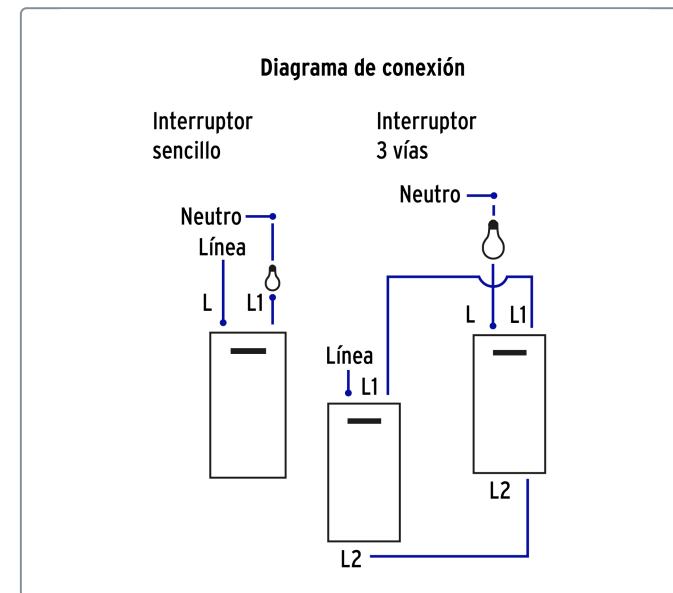
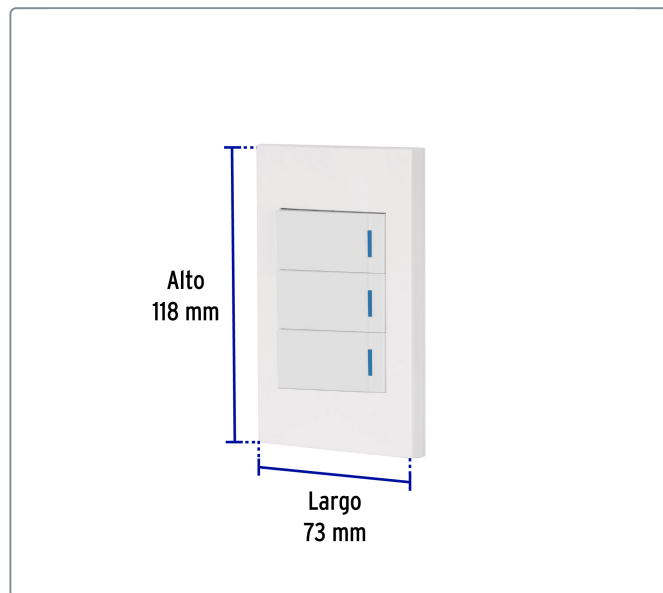
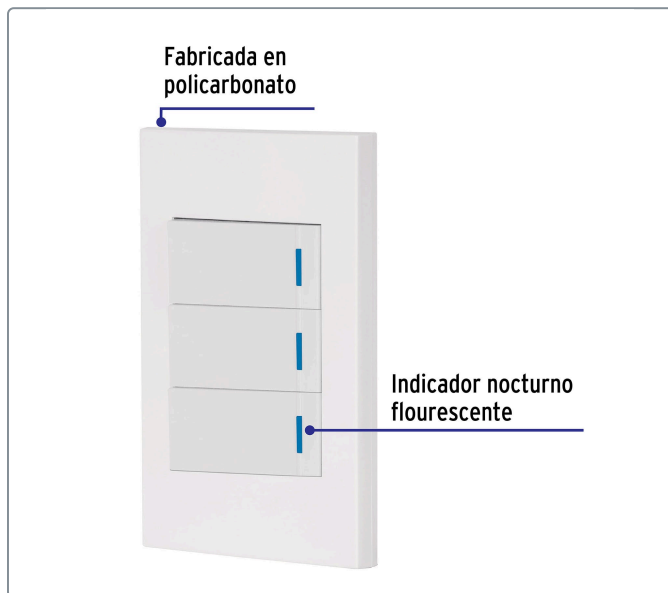

**EMPAQUE MASTER**

**Alto**  
**34 cm**  
(13 1/2'')

**Ancho**  
**27.2 cm**  
(10 1/2'')

**Largo**  
**36.5 cm**  
(14 1/2'')

**Contiene: 24 inner (72 piezas)**

**Peso: 9.24 kg (20.4 lb)**