

TRUPER



CÓDIGO: CLAVE: BSM-P

Brocas para concreto SDS Plus, mm

- Punta de cruz, tecnología con doble inserto de carburo para mayor precisión de perforación, 2X mayor durabilidad que las brocas convencionales
- Cuerpo de acero al cromo que ofrece mayor resistencia al calentamiento
- Zanco compatible con la mayoría de rotomartillos SDS plus
- Diseñada para evitar que se atore durante la perforación
- Empaque para prevenir el óxido en zonas de alta salinidad

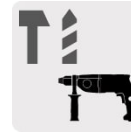
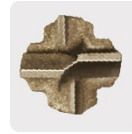
**Especificaciones**

Diámetro	8 mm
Largo total	110 mm
Longitud de trabajo	42 mm
Empaque individual	Tubo con etiqueta

País de origen**Fabricado en China bajo las estrictas especificaciones de GRUPO TRUPER**

Imágenes complementarias

