

VOLTECK



CÓDIGO: 47845 CLAVE: PA-APCO1-LA

## Placa armada acero interruptor y contacto 1 módulo, Lisboa

- Fabricadas en policarbonato y acero inoxidable
- Chasis de acero



### Certificaciones y garantías

- Cumple la norma: NOM-003-SCFI



### Especificaciones

<b>Interruptor: Tensión / Corriente</b>	127 V / 10 A
<b>Contacto: Tensión / Corriente</b>	127 V / 15 A
<b>Empaque individual</b>	Bolsa
<b>Inner</b>	3
<b>Master</b>	72
<b>Pallet</b>	2880

### País de origen

Producto fabricado en China bajo las estrictas especificaciones de Truper

Imágenes complementarias



Diagrama de conexión



EMPAQUE INDIVIDUAL

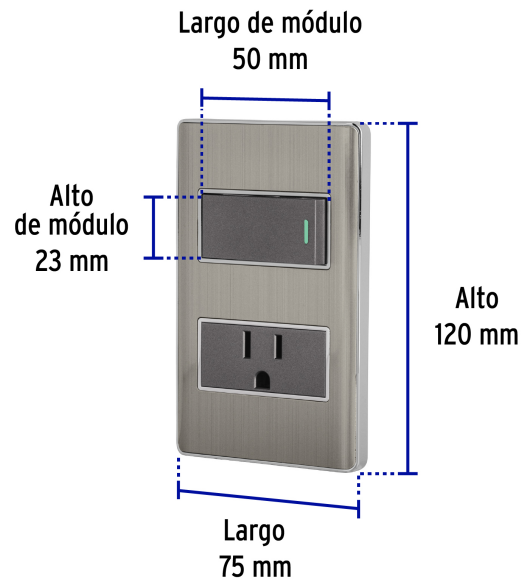
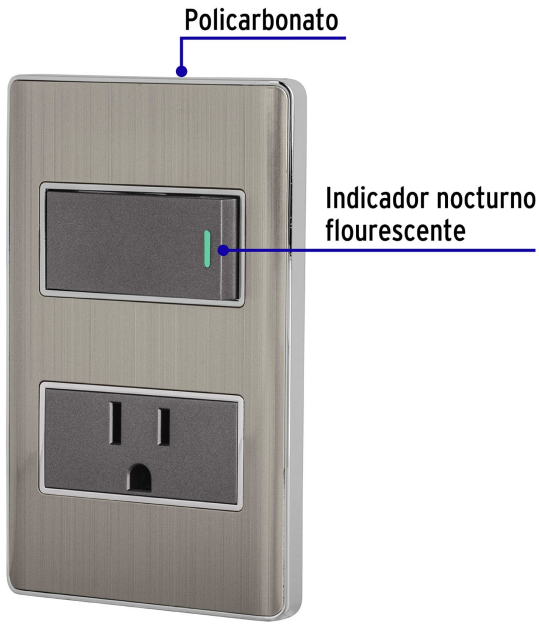
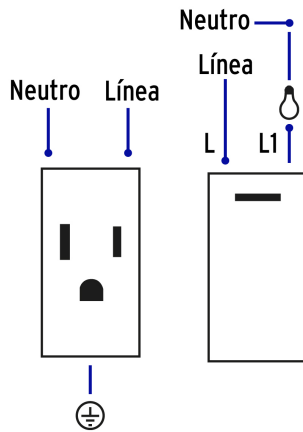

Peso: 0.14 kg (0.3 lb)

**Imágenes complementarias**

**EMPAQUE INNER**



Contiene: 3 piezas

Peso: 0.45 kg (1 lb)

**EMPAQUE MASTER**



Contiene: 24 inner (72 piezas)

Peso: 11.18 kg (24.7 lb)

