

VOLTECK CÓDIGO: 40016 CLAVE: PA-CODO-CLP

Placa armada contacto dúplex, 2 polos + tierra Classic

- Fabricado en policarbonato



Para interior



Incluye
tornillería



Contacto
aterrizado



Retardante
a la flama

Datos de empaque

Empaque individual: Bolsa

Empaque logístico	Cantidad
-------------------	----------

Inner	3
-------	---

Máster	48
--------	----

Pallet	2592
--------	------

Certificaciones y garantías



- Cumple la norma: NOM-003-SCFI

Producto fabricado en China bajo las estrictas especificaciones de Truper

Especificaciones técnicas

Tensión / Frecuencia	127 V / 60 Hz
----------------------	---------------

Corriente	15 A
-----------	------

Diagrama de conexión

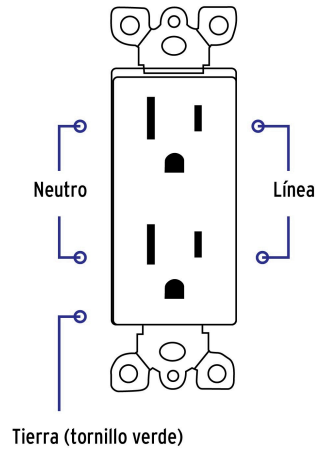

EMPAQUE INDIVIDUAL



Peso: 0.07 kg (0.2 lb)

EMPAQUE INNER



Contiene: 3 piezas

Peso: 0.24 kg (0.5 lb)

EMPAQUE MASTER



Contiene: 16 inner (48 piezas)

Peso: 4.2 kg (9.3 lb)