

VOLTECK CÓDIGO: 40018 CLAVE: PA-COAP-CLP

Placa armada contacto e interruptor Classic, VOLTECK

- Fabricado en policarbonato



Especificaciones técnicas	
Interruptor: Tensión / Frecuencia	120 V / 60 Hz
Contacto: Tensión / Frecuencia	127 V / 60 Hz
Corriente	15 A

Datos de empaque	
Empaque individual: Bolsa	
Empaque logístico	Cantidad
Inner	3
Máster	48
Pallet	1872

Certificaciones y garantías



- Cumple la norma: NOM-003-SCFI

Producto fabricado en China bajo las estrictas especificaciones de Truper

Diagrama de conexión

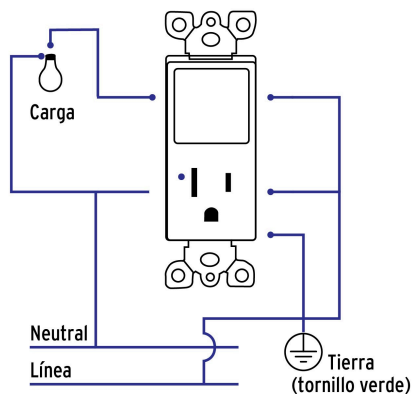

Largo
115 mm



Ancho
70 mm



EMPAQUE INDIVIDUAL

Alto
21 cm
(8 1/2")



Largo
11 cm
(4 1/2")

Peso: 0.09 kg (0.2 lb)

EMPAQUE INNER

Alto
9.2 cm
(3 1/2")



Ancho
12.2 cm
(5 1/2")

Largo
14.5 cm
(5")

Contiene: 3 piezas

Peso: 0.32 kg (0.7 lb)

EMPAQUE MASTER

Alto
31.3 cm
(12 1/2")



Ancho
25.5 cm
(10")

Largo
40.5 cm
(16")

Contiene: 16 inner (48 piezas)

Peso: 5.34 kg (11.8 lb)