

VOLTECK CÓDIGO: 46488 CLAVE: PA-APCO-02B

Placa armada contacto y 2 interruptores, línea Oslo, blanco

- Fabricada en ABS, polipropileno y policarbonato

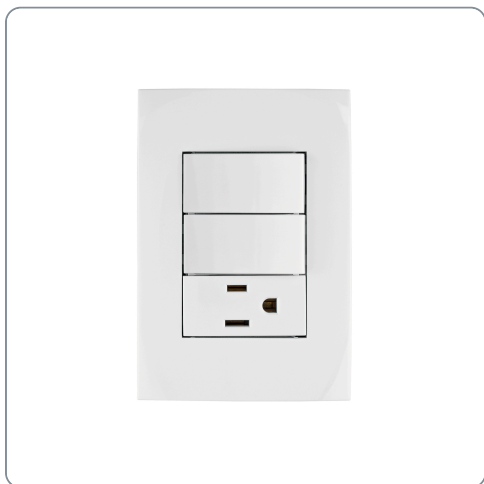

Especificaciones técnicas

Interruptor: Tensión / Corriente	125 V / 10 A
Contacto: Tensión / Corriente	127 V / 16 A

Datos de empaque

Empaque individual: Bolsa

Empaque logístico	Cantidad
-------------------	----------

Inner	3
-------	---

Máster	72
--------	----

Pallet	1944
--------	------

Certificaciones y garantías



- Cumple la norma: NOM-003-SCFI

Producto fabricado en China bajo las estrictas especificaciones de Truper

Diagrama de conexión

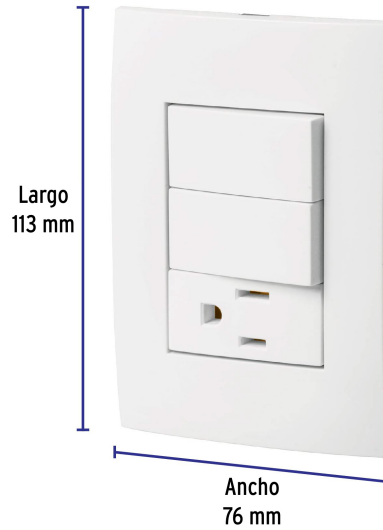
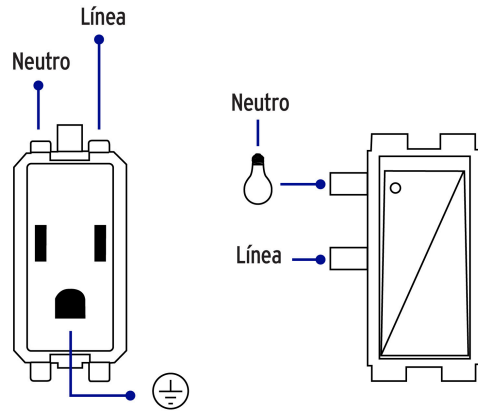

EMPAQUE INDIVIDUAL



Peso: 0.09 kg (0.2 lb)

EMPAQUE INNER



EMPAQUE MASTER

