

VOLTECK CÓDIGO: 46007 CLAVE: APTR-CL

Interruptor triple, línea Classic, VOLTECK

- Fabricados en policarbonato

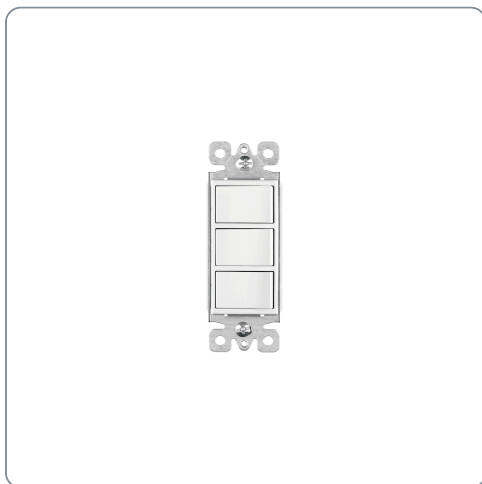



Especificaciones técnicas	
Tipo de interruptor	Triple
Color	Blanco
Tensión / Frecuencia	120 V / 60 Hz
Corriente	15 A
Largo (distancia entre tornillos)	83.3 mm

Datos de empaque	
Empaque Individual: Bolsa	
Empaque logístico	Cantidad
Inner	5
Master	100
Pallet	4000

Certificaciones y garantías

Cumple la norma: NOM-003-SCFI

Fabricado en China bajo las estrictas especificaciones de GRUPO TRUPER

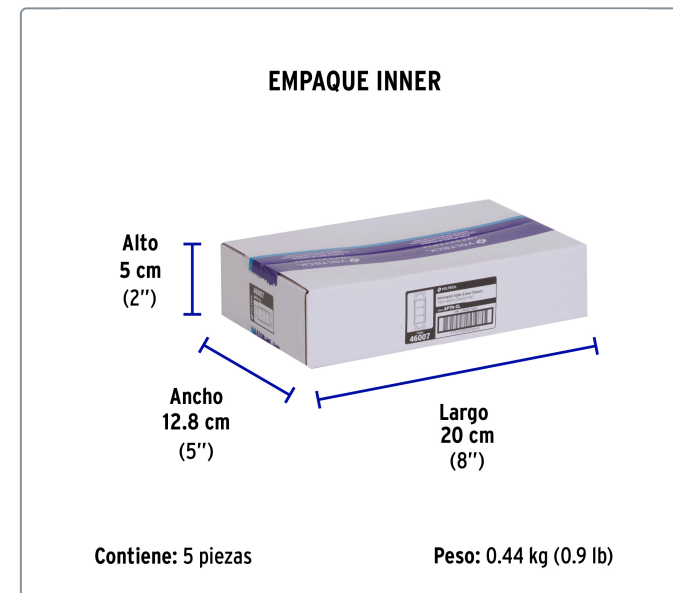
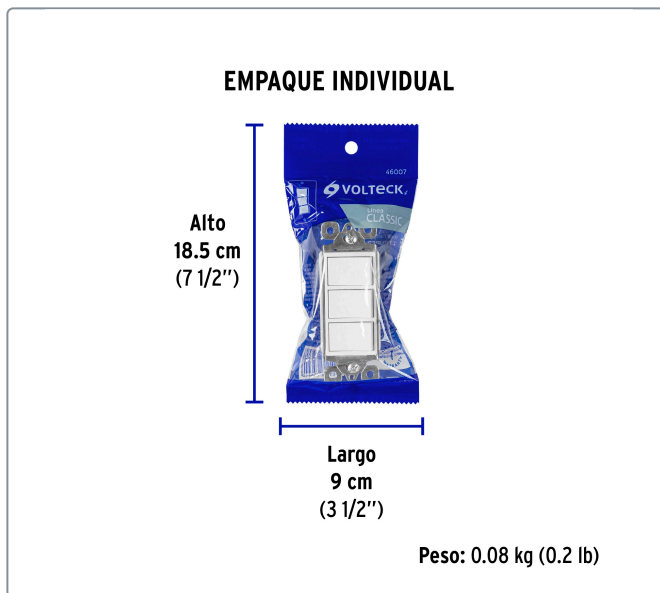
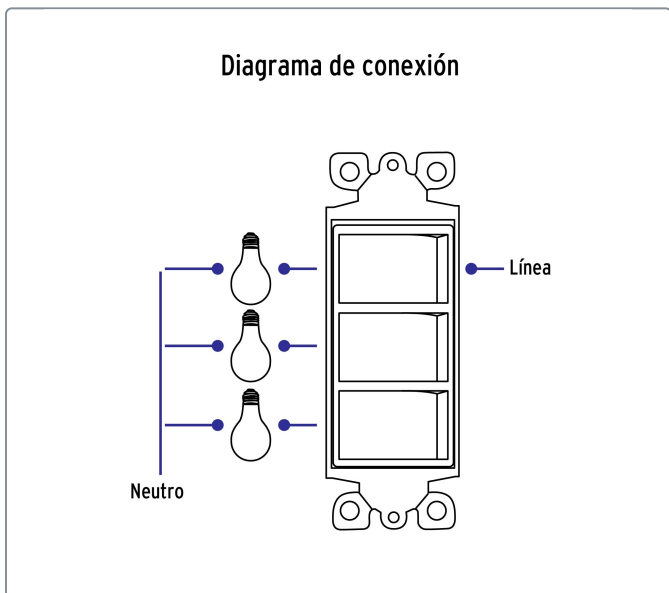
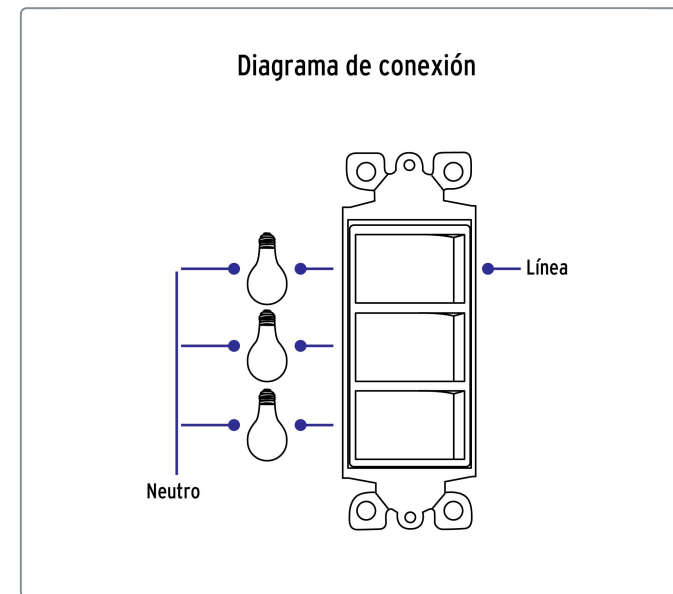
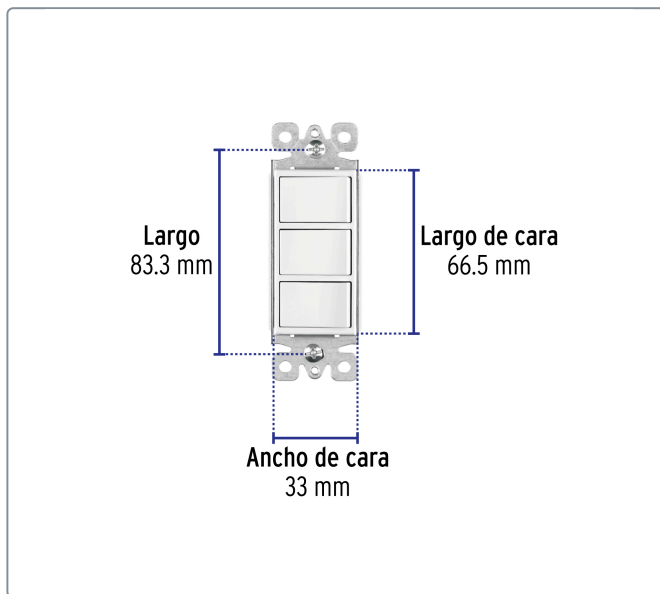

EMPAQUE MASTER



Contiene: 20 inner (100 piezas)

Peso: 9.16 kg (20.2 lb)

