

VOLTECK CÓDIGO: 46008 CLAVE: COAP-CL

Interruptor-contacto, 2 polos + tierra, Classic, VOLTECK

- Fabricado en policarbonato

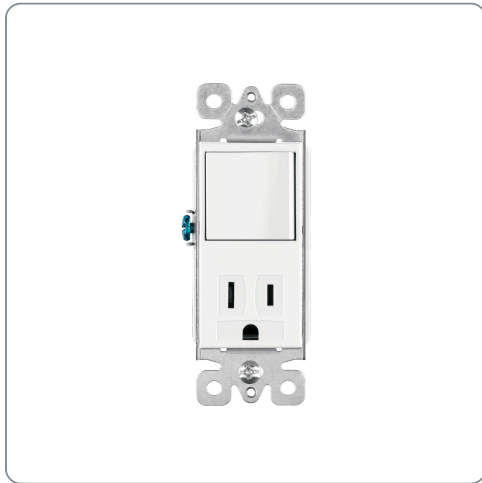

Para interior



Incluye
tornillería



Contacto
aterrizado



Retardante
a la flama

Especificaciones técnicas

Interruptor: Tensión / Corriente / Frecuencia **120 V / 15 A / 60 Hz**

Contacto: Tensión / Corriente / Frecuencia **127 V / 15 A / 60 Hz**

Datos de empaque

Empaque individual: Bolsa

Empaque logístico	Cantidad
-------------------	----------

Inner	5
-------	---

Máster	100
--------	-----

Pallet	4000
--------	------

Certificaciones y garantías

Cumple la norma: NOM-003-SCFI



Producto fabricado en China bajo las estrictas especificaciones de Truper

Diagrama de conexión

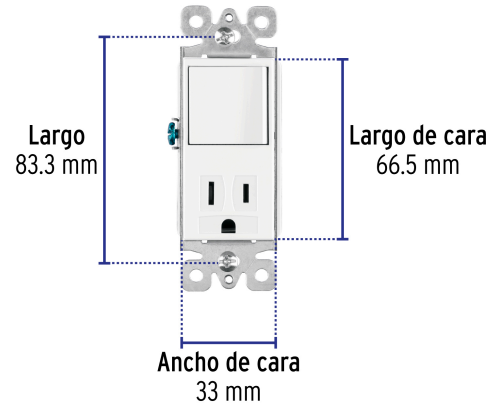
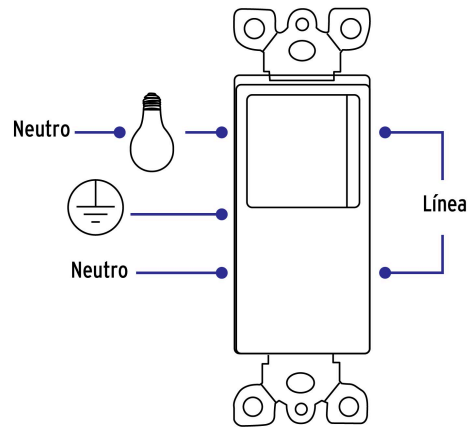

EMPAQUE INDIVIDUAL



Peso: 0.07 kg (0.2 lb)

EMPAQUE INNER

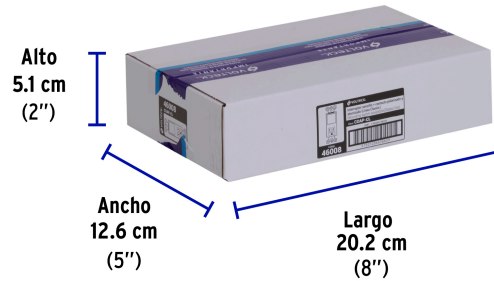

Contiene: 5 piezas

Peso: 0.41 kg (0.9 lb)

EMPAQUE MASTER



Contiene: 20 inner (100 piezas)

Peso: 8.74 kg (19.3 lb)