

VOLTECK

CÓDIGO: 46490 CLAVE: POCO-12

Adaptador de portalámpara a contacto, VOLTECK



- Tensión / Corriente: 127 V / 15 A
- Fabricado de baquelita

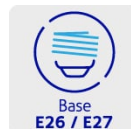

Certificaciones y garantías

- Cumple la norma: NOM-003-SCFI



Especificaciones

Díámetro	1-3/16" (34 mm)
Tensión / Frecuencia	127 V / 60 Hz
Corriente	15 A
Tipo de Base	E26 / E27
Empaque individual	Bolsa
Inner	10
Máster	100
Pallet	6000

País de origen

Fabricado en China bajo las estrictas especificaciones de GRUPO TRUPER

Imágenes complementarias

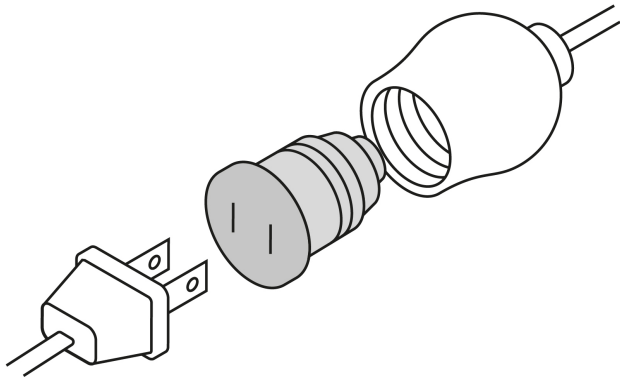

Convierte portalámpara a contacto



EMPAQUE INDIVIDUAL

Alto
17 cm
(6 1/2")



Largo
7.5 cm
(3")

Peso: 0.01 kg (0.02 lb)

Imágenes complementarias

EMPAQUE INNER



Contiene: 10 piezas

Peso: 0.19 kg (0.4 lb)

EMPAQUE INNER



Contiene: 10 piezas

Peso: 0.19 kg (0.4 lb)

EMPAQUE MASTER

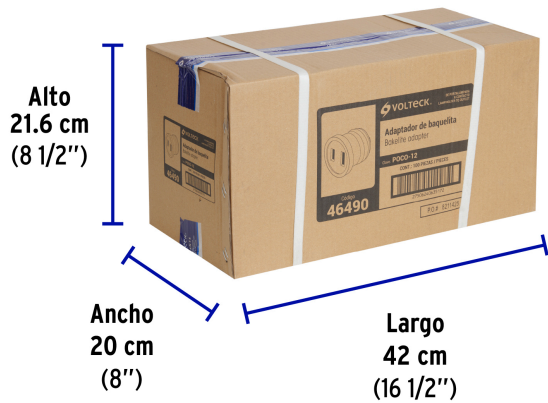

Contiene: 10 inner (100 piezas)

Peso: 2.14 kg (4.7 lb)

EMPAQUE MASTER



Contiene: 10 inner (100 piezas)

Peso: 2.14 kg (4.7 lb)