

VOLTECK



CÓDIGO: 46519 CLAVE: POPL-10

Portalámpara de baquelita, 3-1/2", VOLTECK

- Tensión / Corriente: 250 V / 4 A
- Casquillo de aluminio
- Base redonda atornillable de sobreponer para fijar en pared o techo

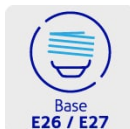

Para interior

Base
E26 / E27Retardante
a la flama**Certificaciones y garantías**

- Cumple la norma: NOM-003-SCFI

**Especificaciones**

Díámetro	3-1/2" (90 mm)
Tensión / Frecuencia	250 V / 60 Hz
Corriente	4 A
Tipo de Base	E26 / E27
Empaque individual	Bolsa
Inner	10
Master	100
Pallet	3000

País de origen**Fabricado en China bajo las estrictas especificaciones de GRUPO TRUPER**

Imágenes complementarias

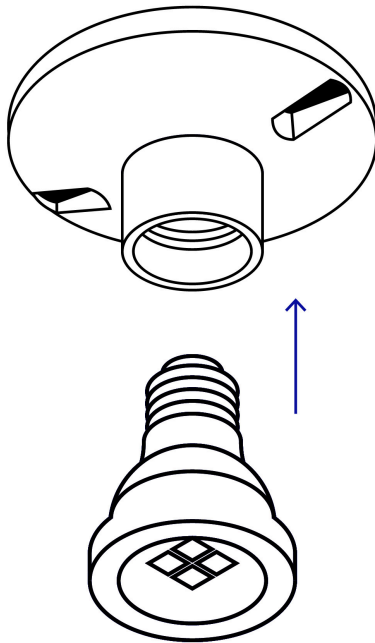
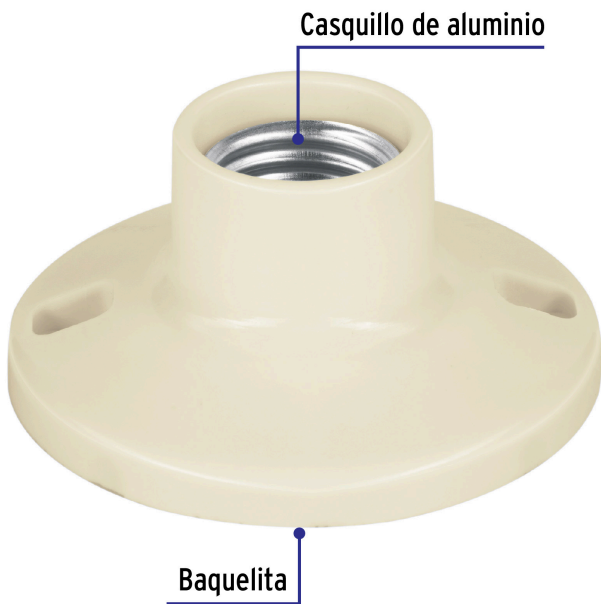

EMPAQUE INDIVIDUAL



Largo
11.4 cm
(4 1/2")

Peso: 0.05 kg (0.1 lb)

Imágenes complementarias

EMPAQUE INNER



Contiene: 10 piezas

Peso: 0.62 kg (1.4 lb)

EMPAQUE MASTER

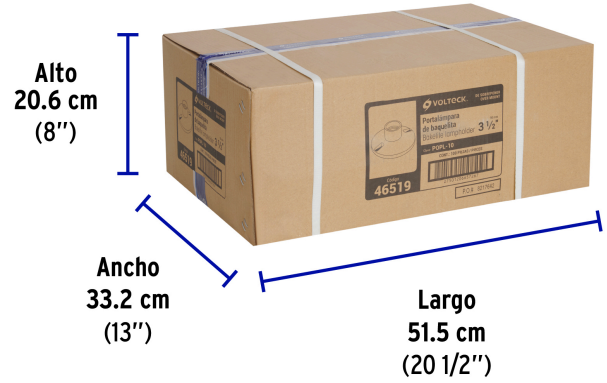

Contiene: 10 inner (100 piezas)

Peso: 6.7 kg (14.8 lb)

