

FOSET

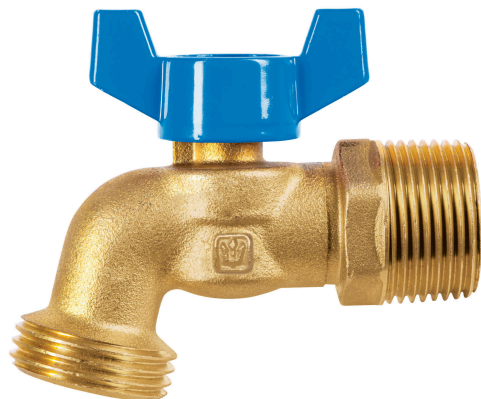

CÓDIGO: 49054 CLAVE: LLE-151L

Llave de esfera de latón 3/4" con rosca para manguera, FOSET

- Fabricada de latón para máxima duración
- Maneral de aluminio tipo mariposa
- Esfera de acero
- Cierre 1/4 de vuelta
- Conexión interna de 1/2" (13 mm)

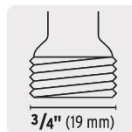
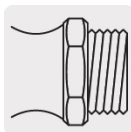

Certificaciones y garantías

- Garantizado contra defectos de fabricación o mano de obra. La garantía se puede hacer válida con cualquier distribuidor de TRUPER

Especificaciones

Presión máxima	6 kgf/cm ²
Conexión de entrada	3/4" - 14 NPT
Conexión de salida	3/4" - 11.5 NH (3 hilos)
Peso	168 g
Empaque individual	Etiqueta
Inner	6
Master	48
Pallet	4608

País de origen

Fabricado en China bajo las estrictas especificaciones de GRUPO TRUPER

Imágenes complementarias

